

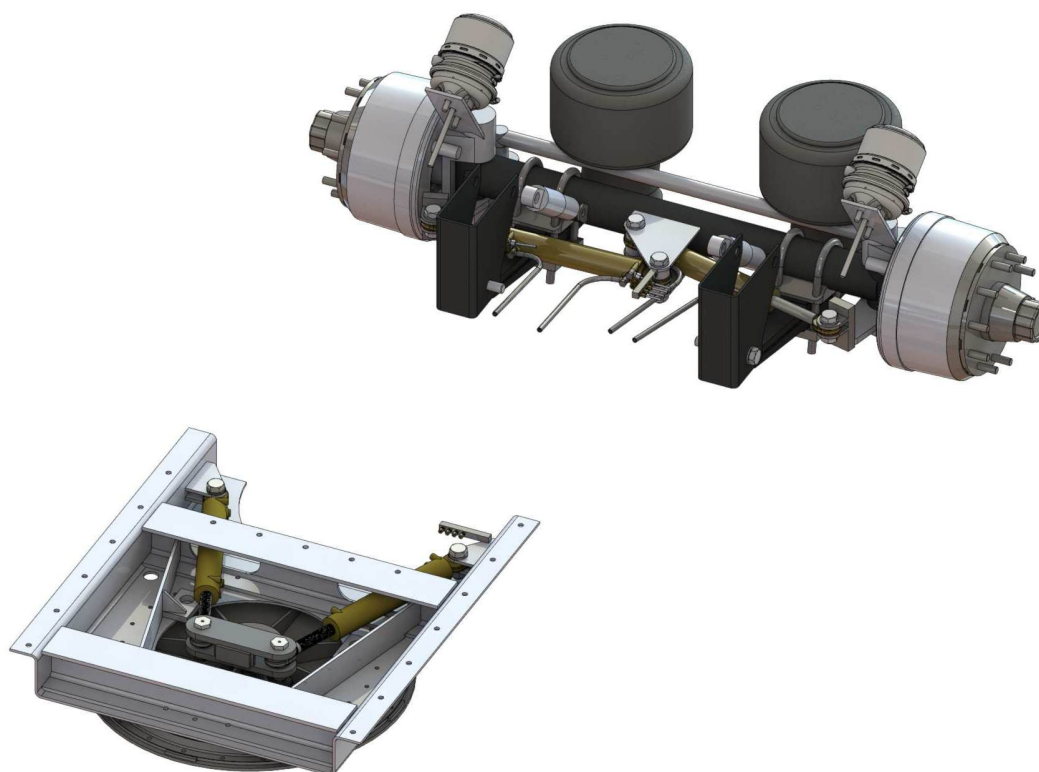

## Installation manual

### EB-18 / TB-18 TYPE B



ESVE B.V.  
Albert Schweitzerstraat 5  
7131 PG Lichtenvoorde NL  
tel.: 0031 544-392450  
fax.: 0031 544-375415  
mail: [info@esve.nl](mailto:info@esve.nl)  
internet: [www.esve.nl](http://www.esve.nl)



## Installation manual for the ESVE command steering EB-18 / TB-18

### Mounting the steering unit:

The steering unit has to be placed under the chassis, using fourteen bolts M16 quality 8.8, tightened with 210 Nm torque. (see fig.1).

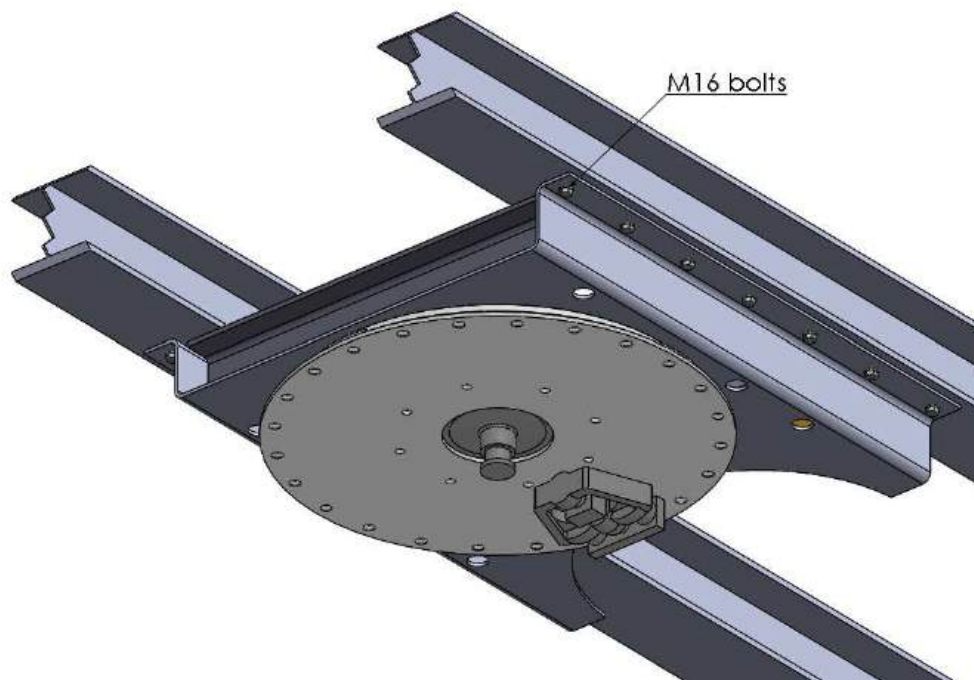

Fig. 1

To relieve the bolts from shearing forces, plates have to be welded before and behind the mounting strip (see fig. 2).

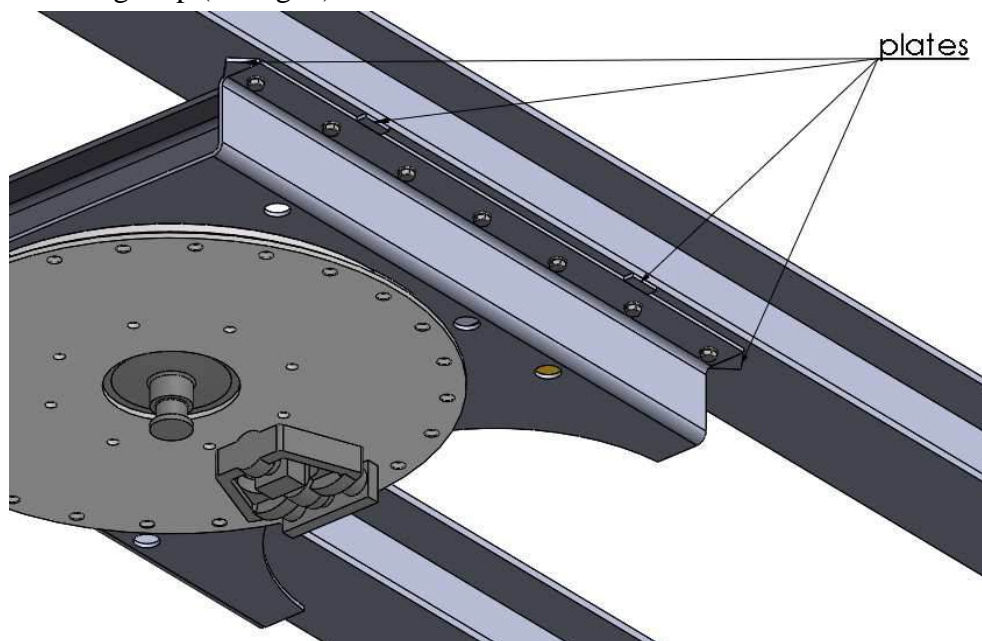

Fig. 2

If the **kingpin** has to be replaced, the eight bolts M14x30 quality 12.9 must be tightened with 190 Nm torque.

If the **steering-wedge** has to be replaced, the nut M32 must be tightened with 400 Nm torque.

If the **hydraulic cylinders** need to be replaced, the M30 quality 8.8 bolts must be tightened with 850 Nm torque.

If the **turn-table** needs to be replaced, the M12 quality 8.8 bolts must be tightened with 87 Nm torque.

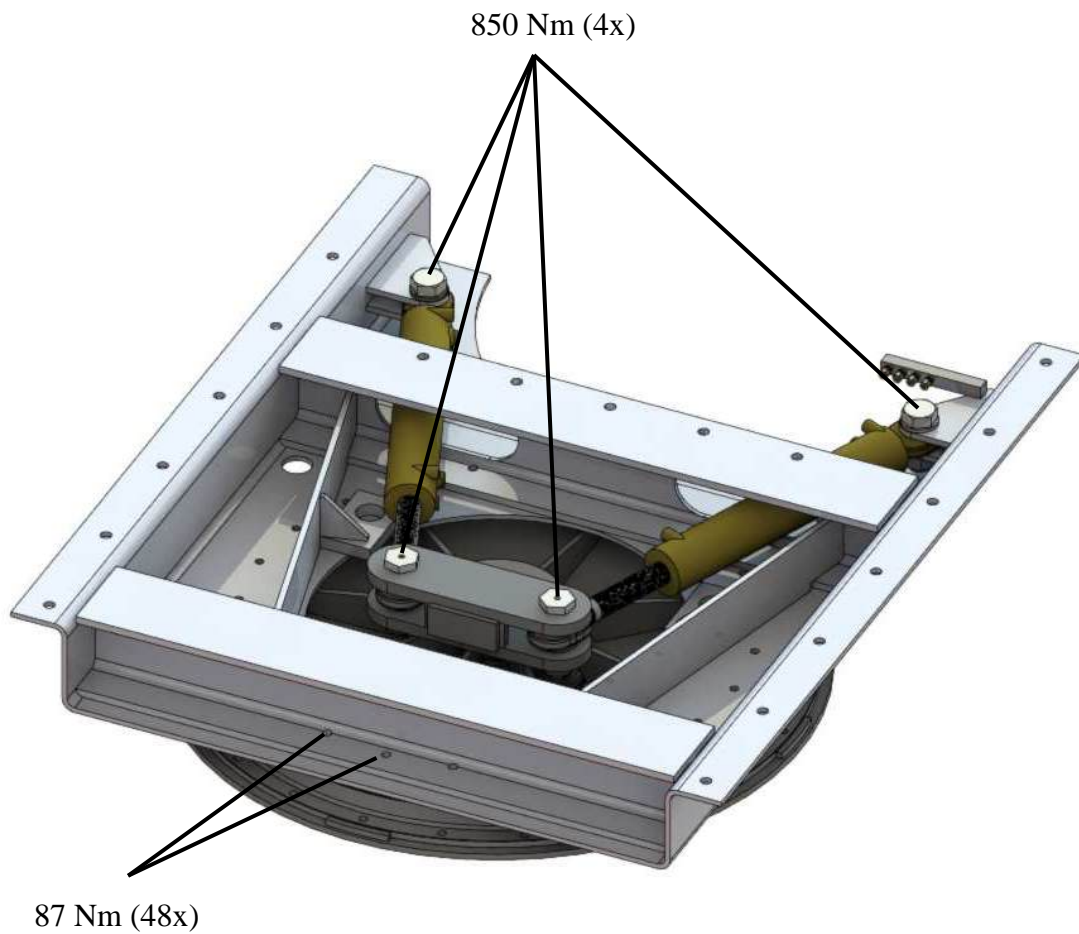

### Mounting the axles:

In mounting the axles one can proceed in the same manner as with normal axles (see fig. 3).

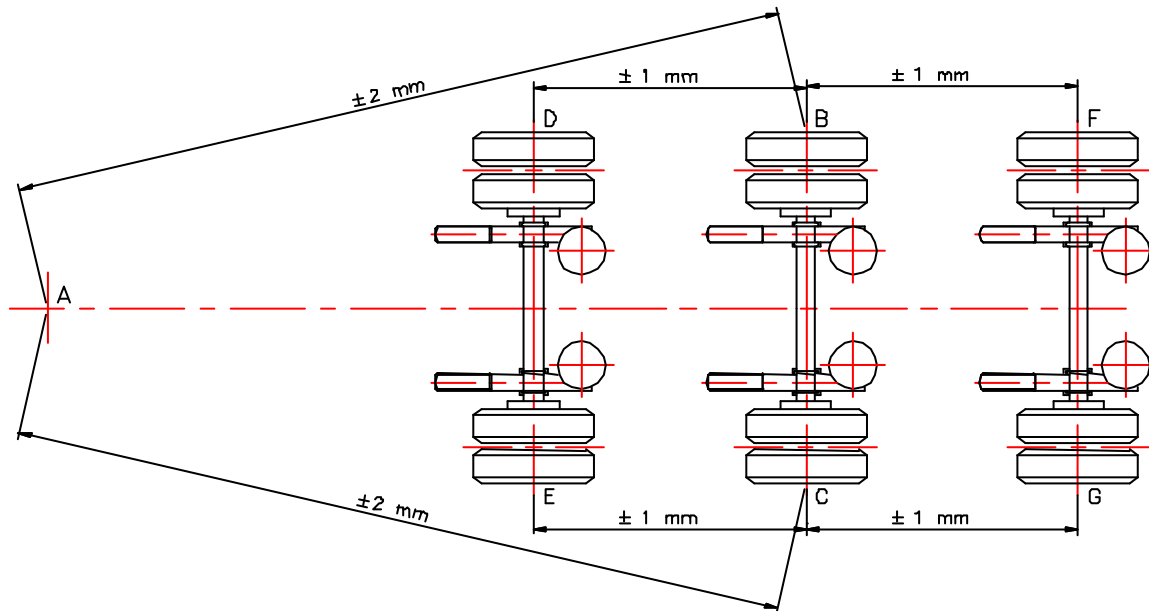

Fig. 3

Be sure that the king pin of the steering axle, when in driving position, are positioned square to the chassis (see fig. 4).

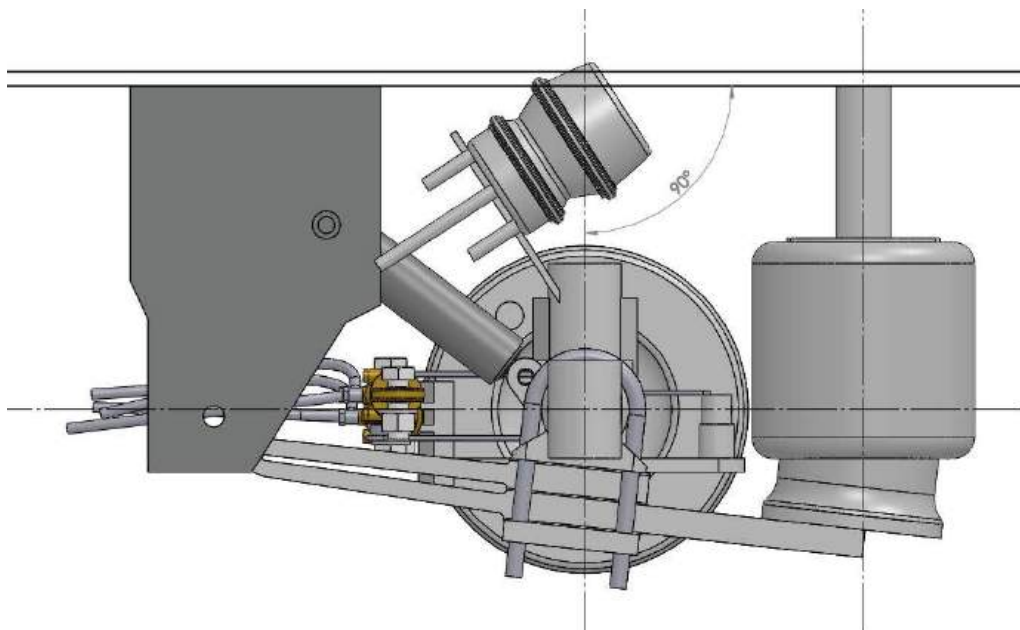

Fig. 4

**If the king pin, when in driving position, are not placed square to the chassis, enormous**

torsion of the chassis will appear when steering. If it occurs, after welding (or screwing) the axles to the chassis, that the axles are not exactly aligned, the axles can be adjusted by unscrewing the spring-stirrups and repositioning the axles.

**Never** try to adjust the deviation by adjusting the trackrods of the king pin! (the steering system may be seriously damaged)

### **Mounting the cylinders on the axles:**

There are two options for mounting the cylinders on the axle, as shown in fig. 5 and 6. The option that should be used depends on the size of the axle.

Fig. 5

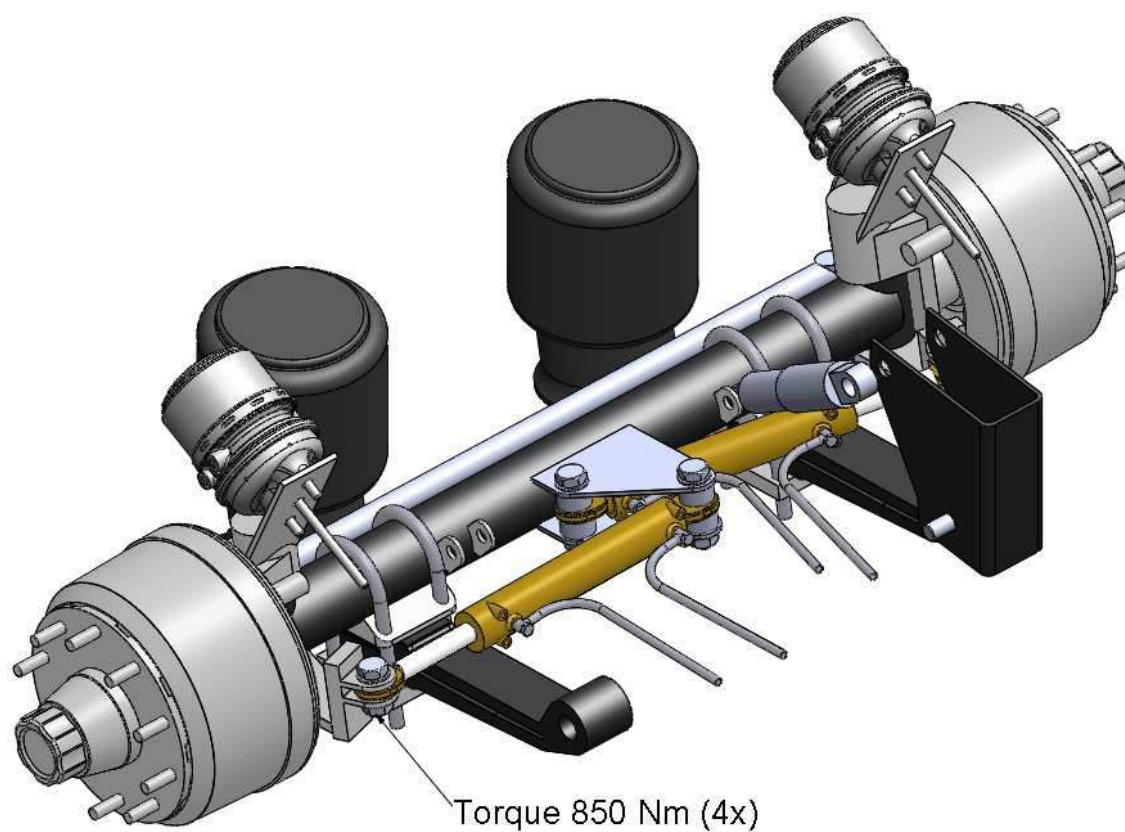

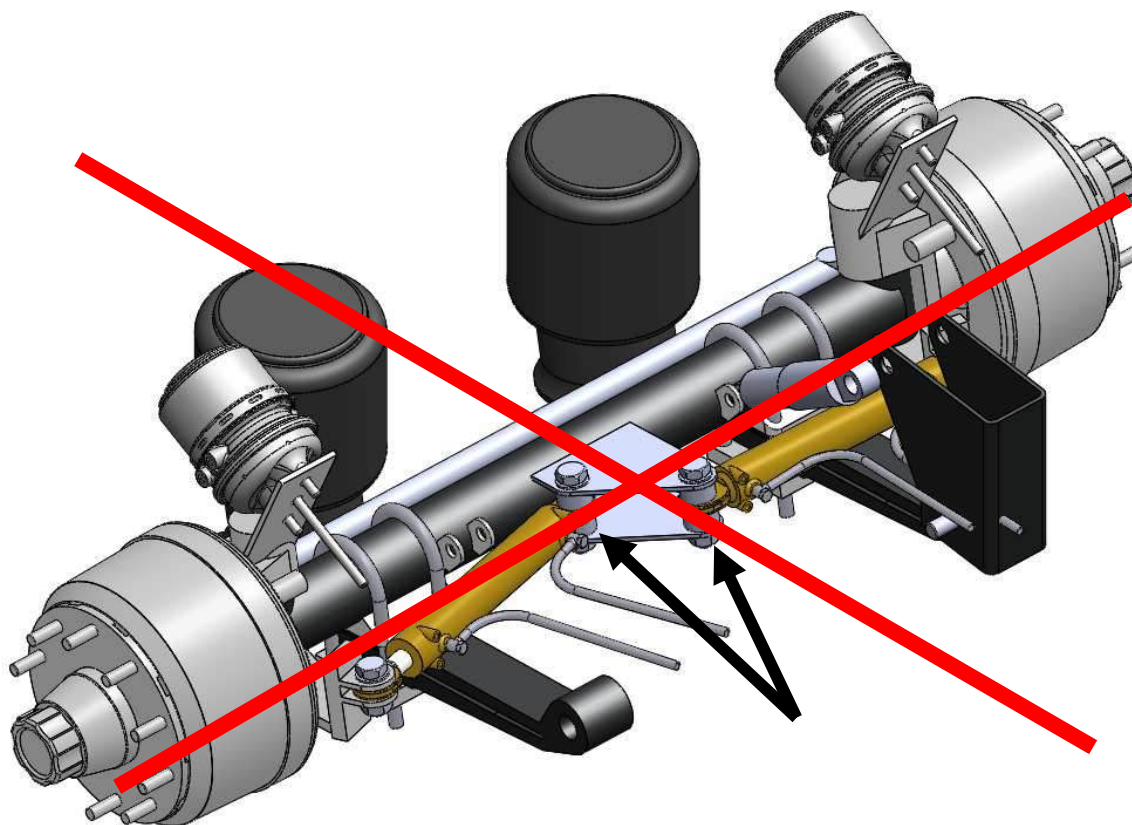
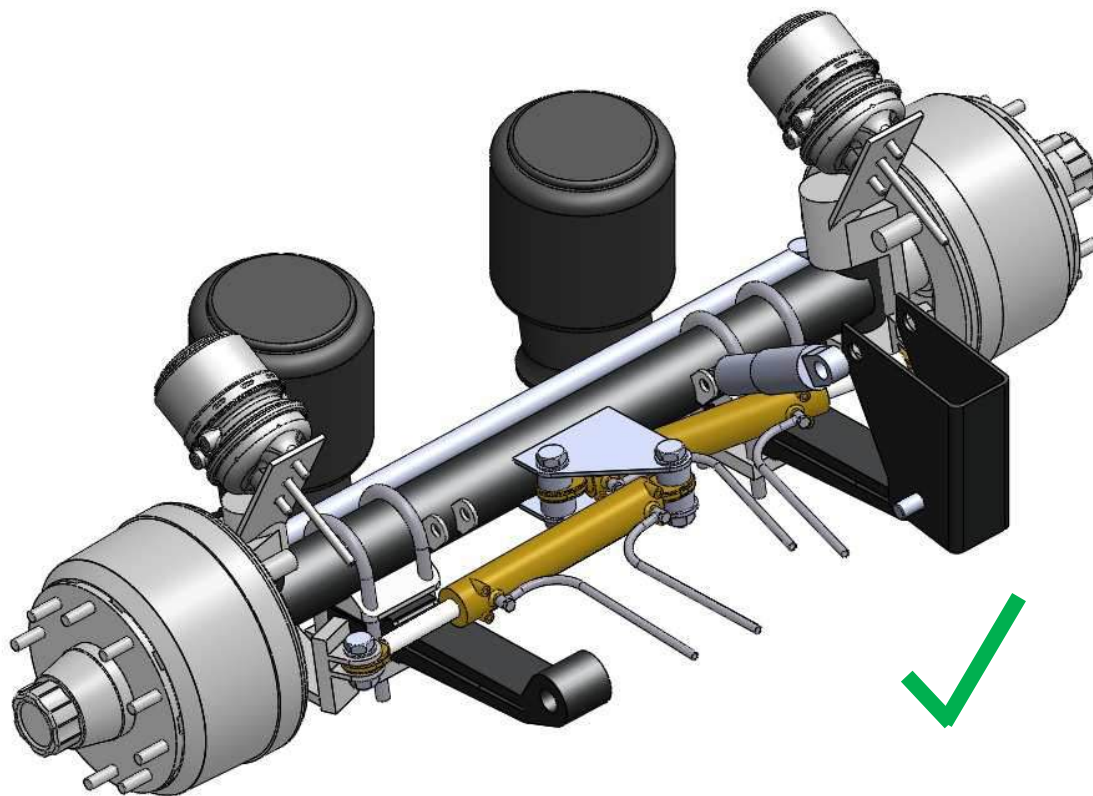

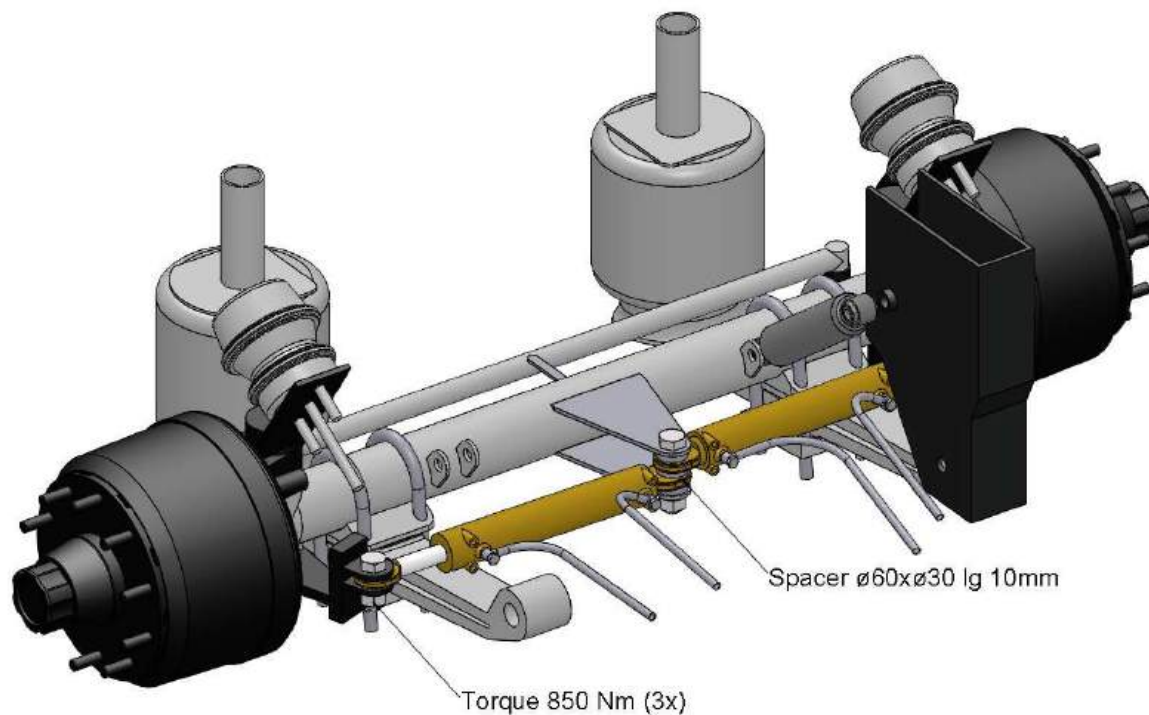

Fig. 6

Be sure that the flexible hoses are mounted as shown on the figures, so they won't be damaged. On the option as showed in fig. 6, there is mounted a spacer between both cylinders.

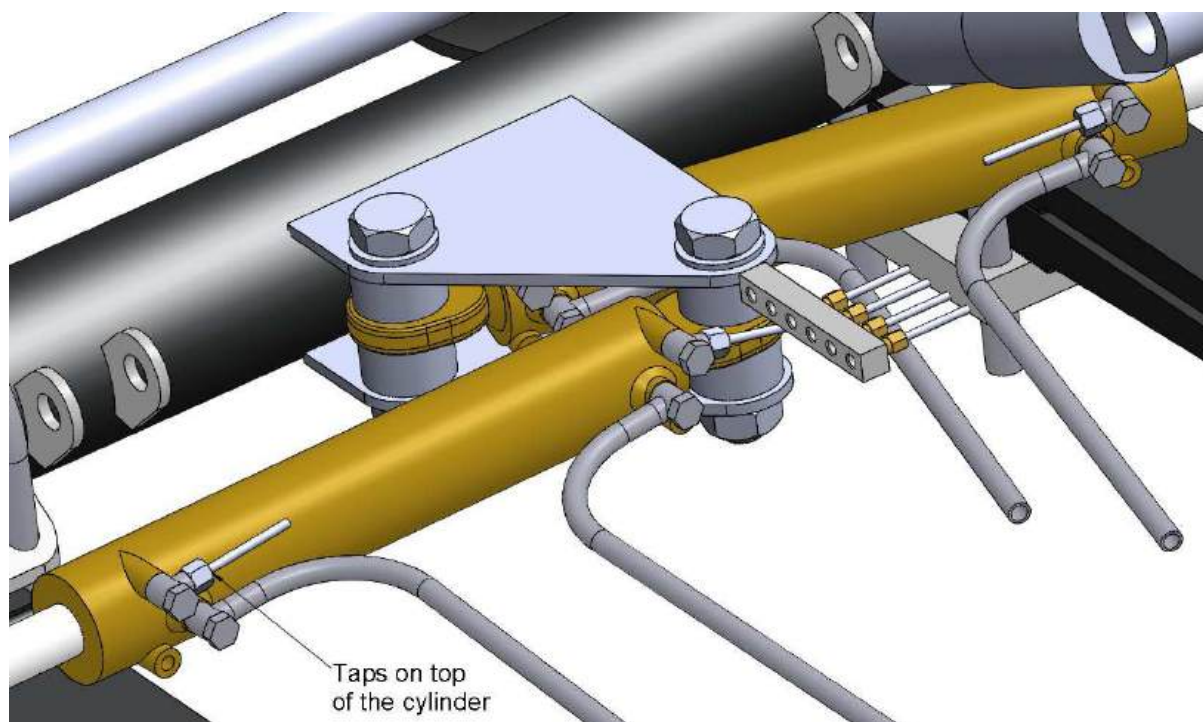

Fig. 7

The bleed taps should be mounted at a central place. The bleed taps are connected to the taps on top of the cylinder (see fig. 7).

**Mounting the pipes:**

The prescribed pipes for the ESVE steering system are steel hydraulics pipes with a minimal bore of  $\varnothing$  9 mm ( for example  $\varnothing$  12x1,5). To the cylinder flexible hoses are mounted, which make it possible for the cylinder to turn slightly. These hoses are included by ESVE.

Connect the steel pipes, according to the hydraulic drawing.

Burrs, dirty parts etc. have to be removed very accurately before the final assembly, for they can cause irreparable damage to the cylinder!

The banjo must be mounted direct to the cylinder, without using any washer or seal.

After fitting the front unit, rear cylinders, control box and the hand pump, connect together using steel pipes.

**Filling and pressurizing the system:**

The prescribed oil with a viscosity of 1.7° Engler at 50° Celsius.

The Hydraulic systems assembled by ESVE are filled with TOTAL H15.

Other oils that meet specifications are:

- ESSO Nuto 15
- Shell Tellus 15
- BP HLP 15
- Mobil DTE 11
- Q 8 H 15

### **Filling the system:**

The system must be filled from the oil tank located **below** the handpump. Remove the filling cap and fill the tank. The required quantity of oil can be read from gauge rod (see filling cap). Place the included hose pillar in the hole of the filling cap (see red circle) and the hose into the oil barrel.

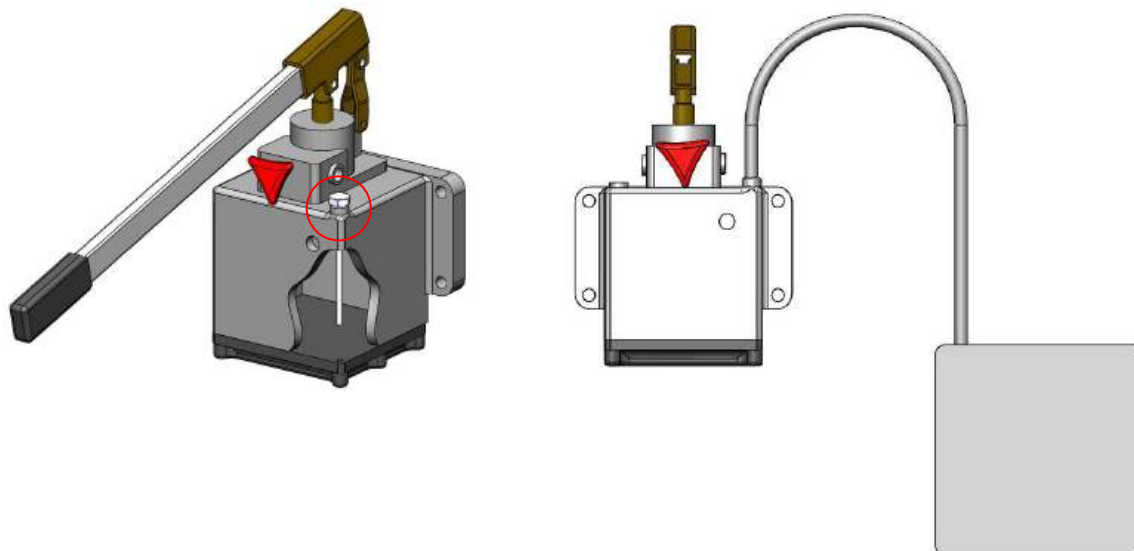

**Fig. 8**

The ball valves, which are located in the control box (see fig. 9 pos.2) must be opened. Proceed by operating the handpump until the pressure gauge reads 40 bar. While pressurizing the system the pressure can not exceed 40 bar, because the pressure valve (see fig. 9 pos.3) opens at 40 bar.

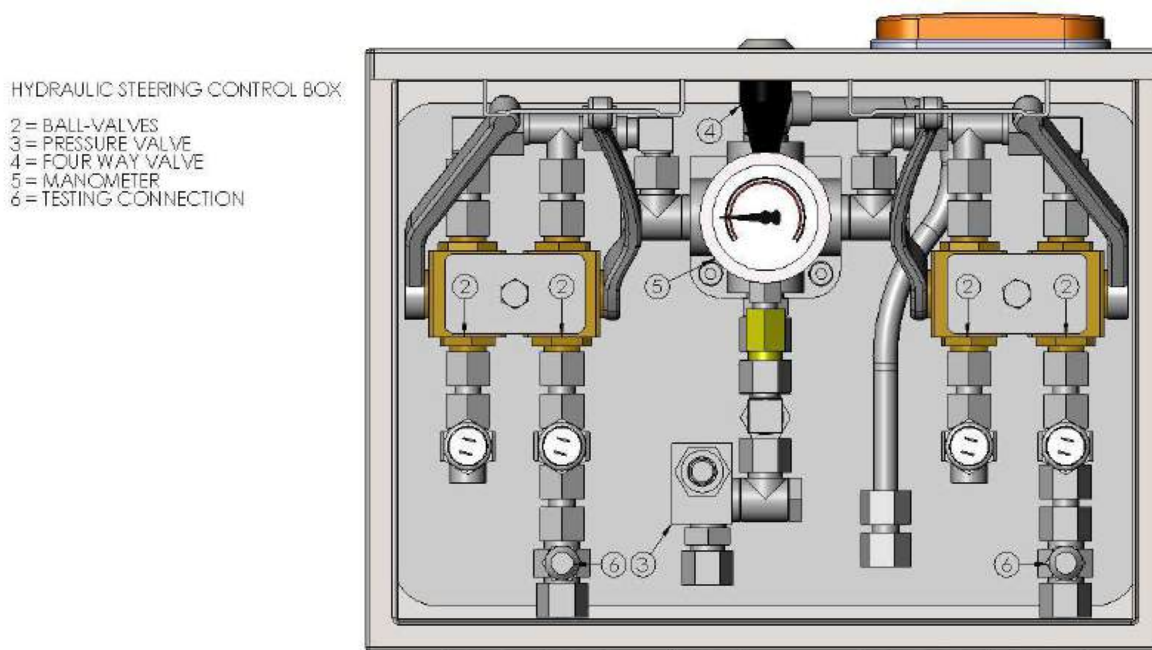

**Fig. 9**

Now open the bleed taps one by one. The bleed taps are placed on a central point and connected to the taps on top of the cylinder (see fig. 10).

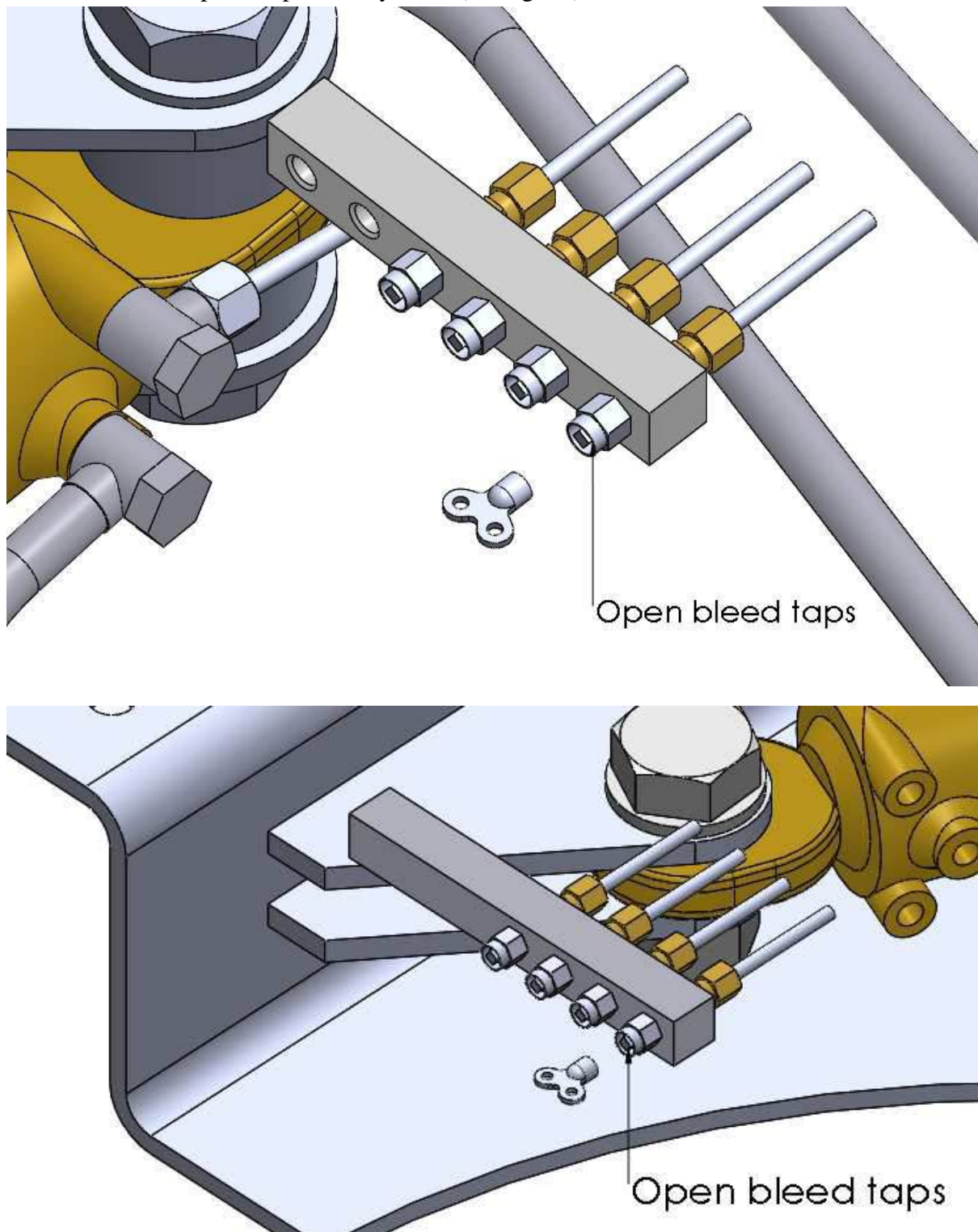

Fig. 10

Keep on pumping until there are no more air bubbles present in the oil (the oiltank is automatically refilled because of the vacuum effect) Make sure the bleed taps are shutdown and repressurize the system to 40 bar. Remove the hose pillar and the hose and replace the filling cap. After the first test-ride the hydraulic system has to be bled once again.

## Testing the system

**After filling , the system has to be checked if the fitting work is done correctly. This is very important because if something is wrong connected, the system can be seriously damaged.**

A square pipe (ca. 2.5 m) has to be placed between the king-pin and the v-plate (see fig. 11). After lifting the steering axle, one person must be able to turn the steering unit. When this is not possible, the system is connected wrong. If this test is successfully, the trailer is ready for his first test-ride.

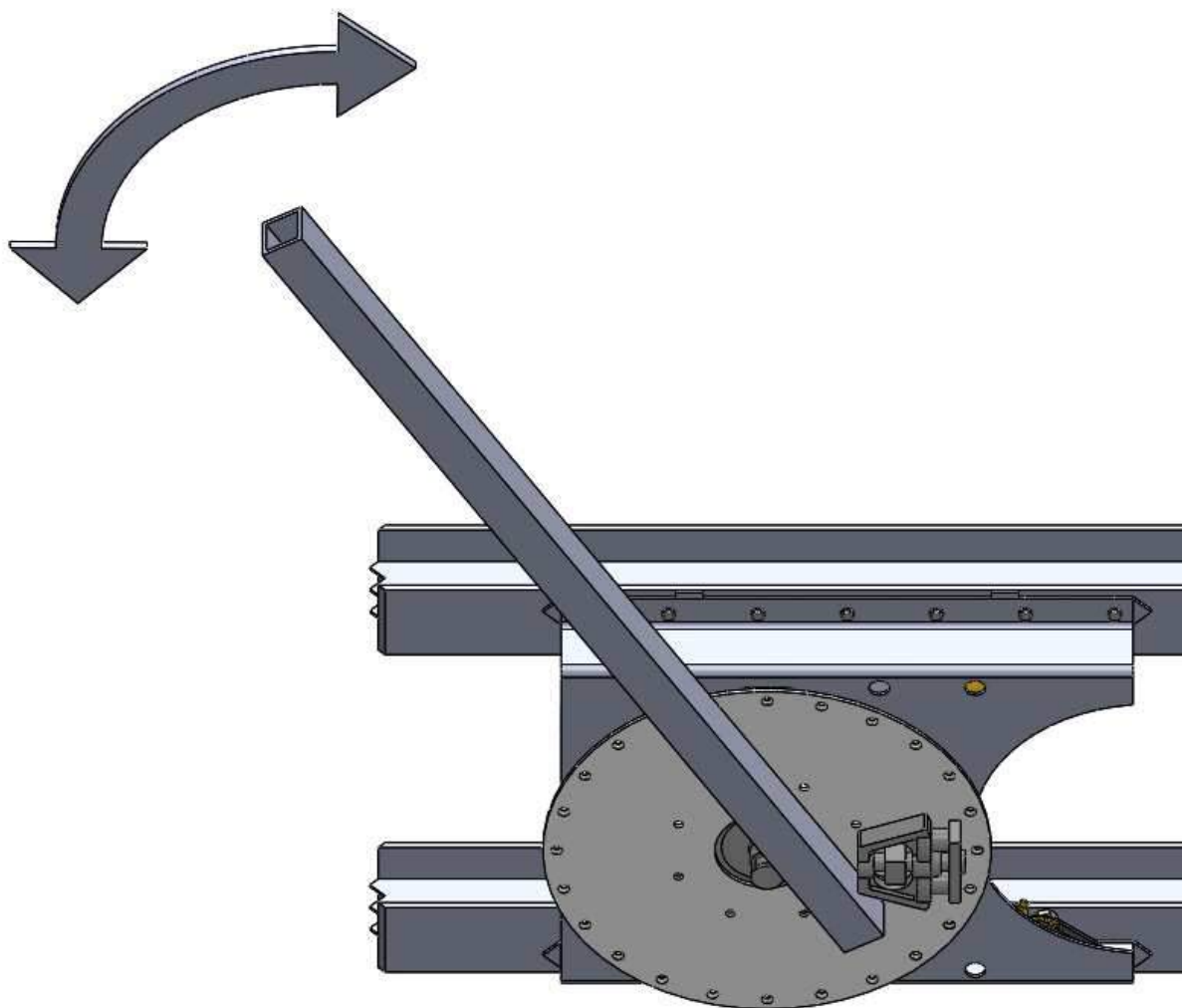

Fig. 11

### **Zero point on the steering axle:**

Put the axle in the zero position. In this position make a marker on the axle (see fig. 12).

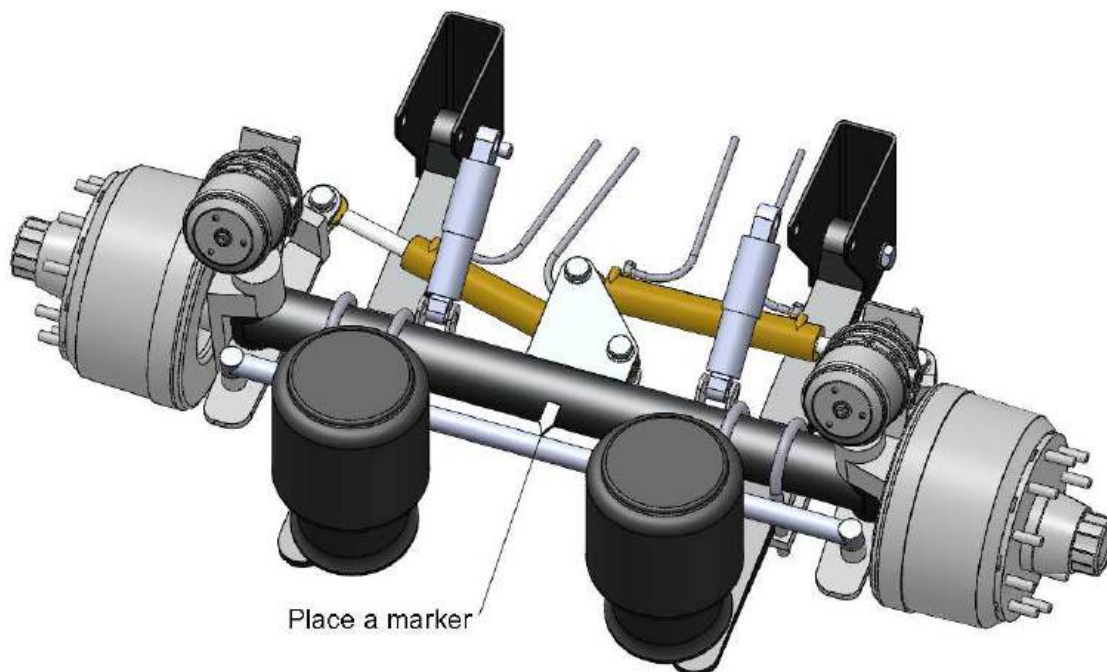

Fig. 12

### **Aligning the trailer to the truck:**

Aligning the trailer to the truck is better done on an even bedding. Place the truck as straight as possible in front of the trailer and make sure that the axle is not turning (see the 'zero-point' on the trackrod).

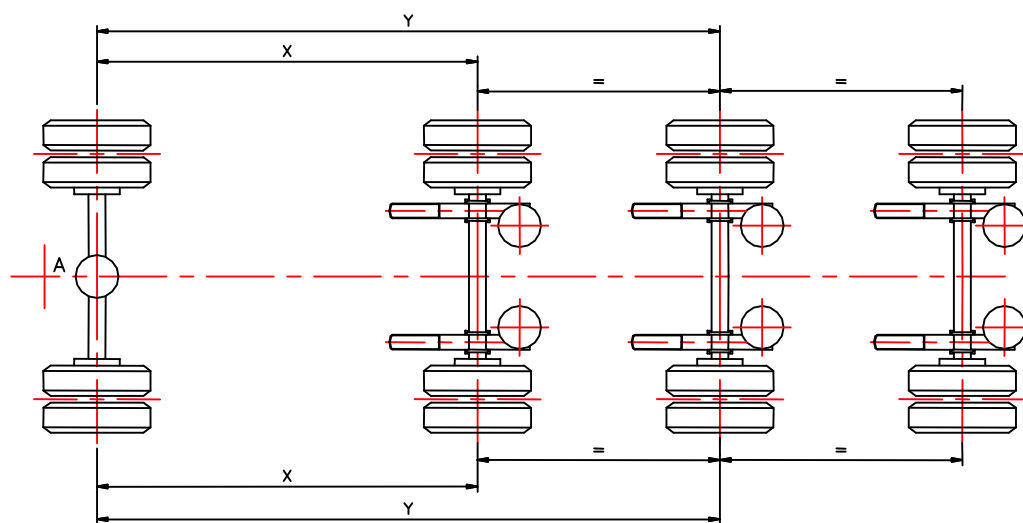

Fig. 13

Now measure the distance from the centre of the rear truck axle to the centre of the swivel axle (see fig. 13).

The measured value, both left and right, must be the same. If this is not the fact, the truck must be maneuvered until rear truck axle and the swivel axle are parallel to each other.

While maneuvering, all ball valves must be opened. After maneuvering check if the swivel axle is still positioned at the 'zero-point'. In case the truck is equipped with a ridged axle, the axle can be used as a measuring point to the trailer axle.

### **Mounting the 'zero-point' to the steering unit:**

After the truck is completely aligned to the trailer a marker has to be placed on the steering unit. This marker allows (a later) easy and quick reading of the exact alignment to the trailer. Fig. 14 shows a few examples for mounting the zero-point. Markers can be placed by using a chisel-centerpoint or by spotwelding a pointed piece of metal.

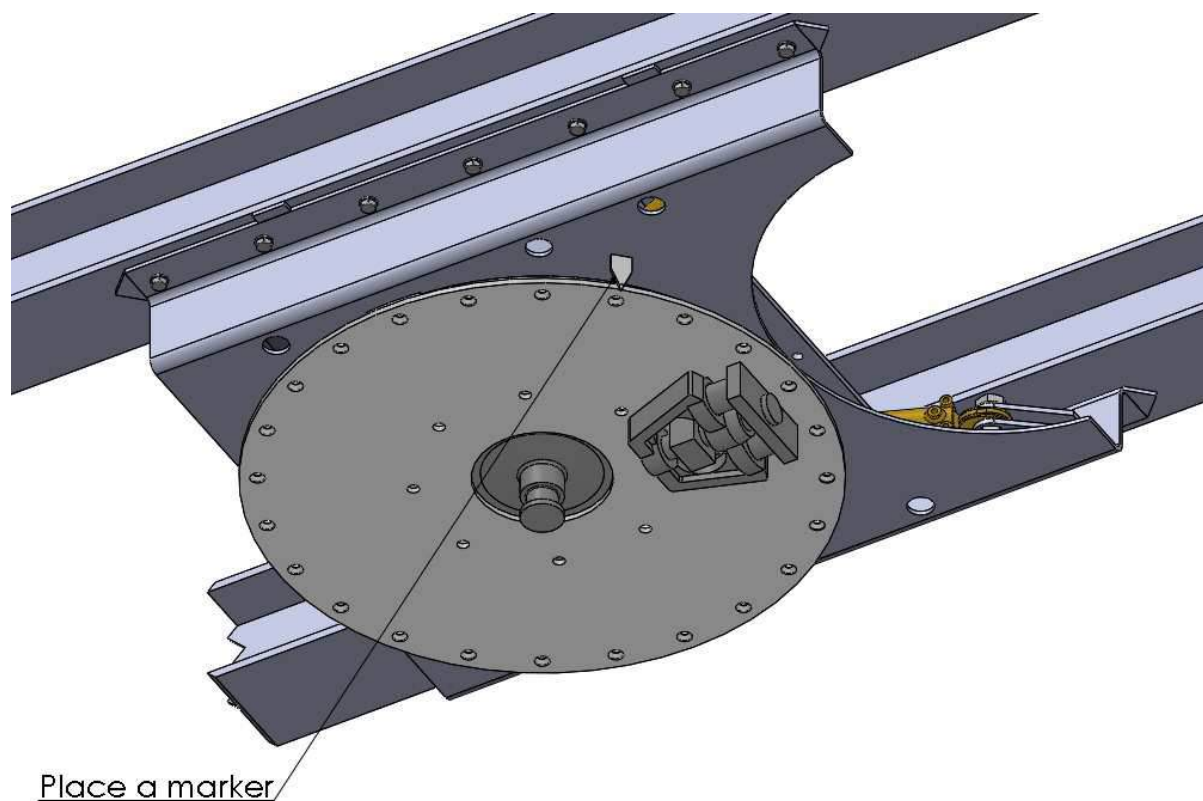

Fig. 14

**How to operate the hydraulic control box:**

The hydraulic control box can be used to align the axle. Check if the truck is positioned straight in front of the trailer (see 'zero-point' on steering unit).

Open all ball valves (see fig. 9 pos. 2).

Place the four-way valve (pos.4) to the left or to the right as necessary and keep pumping until the right position of the wheels is reached. See 'zero-point' on the axles.

Now place the four-way valve to the center position and shutdown all the ball-valves.

**Checking the pre-stressing pressure in the system:**

Turn on the side lights, the control light with the green glass (on the Hydraulic control box) will illuminate. If not, then the prestressing pressure will be too low. This can be cured by opening all ball valves, the four-way valve must be in the middle position, and pumping a few strokes. Shut the valves (check for the axles to stand at the 'zero-point') and close the hydraulic control box. While driving, the hydraulic control box must be closed at all times!

Before every ride, alignment (truck to trailer) has to be checked. See 'zero-points' on the steering unit and the steered axles.

**Maintenance:**

- Every 2 á 4 weeks:
  - \* lubricate the bearing while turning the table of the steering unit.
  - \* lubricate the bearings on the cylinders.
  - \* lubricate (central points on top of) the steering unit.
  - \* lubricate the revolving disc of the steering unit.
  - \* lubricate the steering wedge.
  - \* lubricate the king pin on the axles the trackrod ends.
  - \* see also annex 1.
  
- Every 6 months:
  - \* regrease the bearing.

Use either multi-purpose grease EP2, or (for central lubrication) grease O

- Annually
  - \* Change Hydraulic oil.

- Choose from:
- Mobil DTE 11
  - ESSO Nuto H 15
  - Shell Tellus 15
  - BP HLP 15
  - Q 8 H 15
  - Total H 15.

For every newly installed steering system change Hydraulic oil after 3 months.

**Warning:**

When the steering unit is turned 90 degrees in relation to the trailer the driver will begin to feel a resistance to turning. At this stage the front turntable will be prevented from rotating by a mechanical stop. In order to prevent possible damage the driver must reduce some of his steering angle (lock).

This is especially important when reversing. When the driver should avoid getting the tractor/trailer into a 'Jack knife' position.

**Possible occurring failures:**

- Control light doesn't illuminate:
1. System pressure too low.
  2. Light bulb broken.
  3. Electrical failure.
- Trailer is out of alignment:
1. Axle(s) not properly aligned.
  2. Air in the Hydraulic system.
- Pre-stressing pressure drops:
1. Not enough oil in the system.
  2. Air in the Hydraulic system.
  3. Leakage of:
    - bleed taps on cylinder.
    - joints-hoses-pipes.
- Handpump doesn't work:
1. Not enough oil in the tank.
  2. The valve on the pump hasn't been closed.

ESVE B.V.  
Albert Schweitzerstraat 5  
7131 PG LICHTENVOORDE NL  
tel.: 0031 544 392450  
fax : 0031 544 375415  
mail: info@esve.nl  
internet: [www.esve.nl](http://www.esve.nl)

## Greasing points



**MAINTENANCE: GREASE EVERY 2-4 WEEKS**

(WHEN USING AN AUTOMATIC GREASING SYSTEM, DON'T USE POINT NR. 8, 9, 10 AND 11)

- 1: GREASING POINT V-PLATE**
- 2-5: GREASING POINTS INSIDE THE BEARING**
- 6-7: GREASING POINTS BALL-BEARING STEERING UNIT**
- 8-11: GREASING POINTS OUTSIDE THE BEARING**
- 10-13: GREASING POINTS BALL-BEARING STEERING UNIT**
- 14-17: GREASING POINTS BALL-BEARING STEERING AXLE**

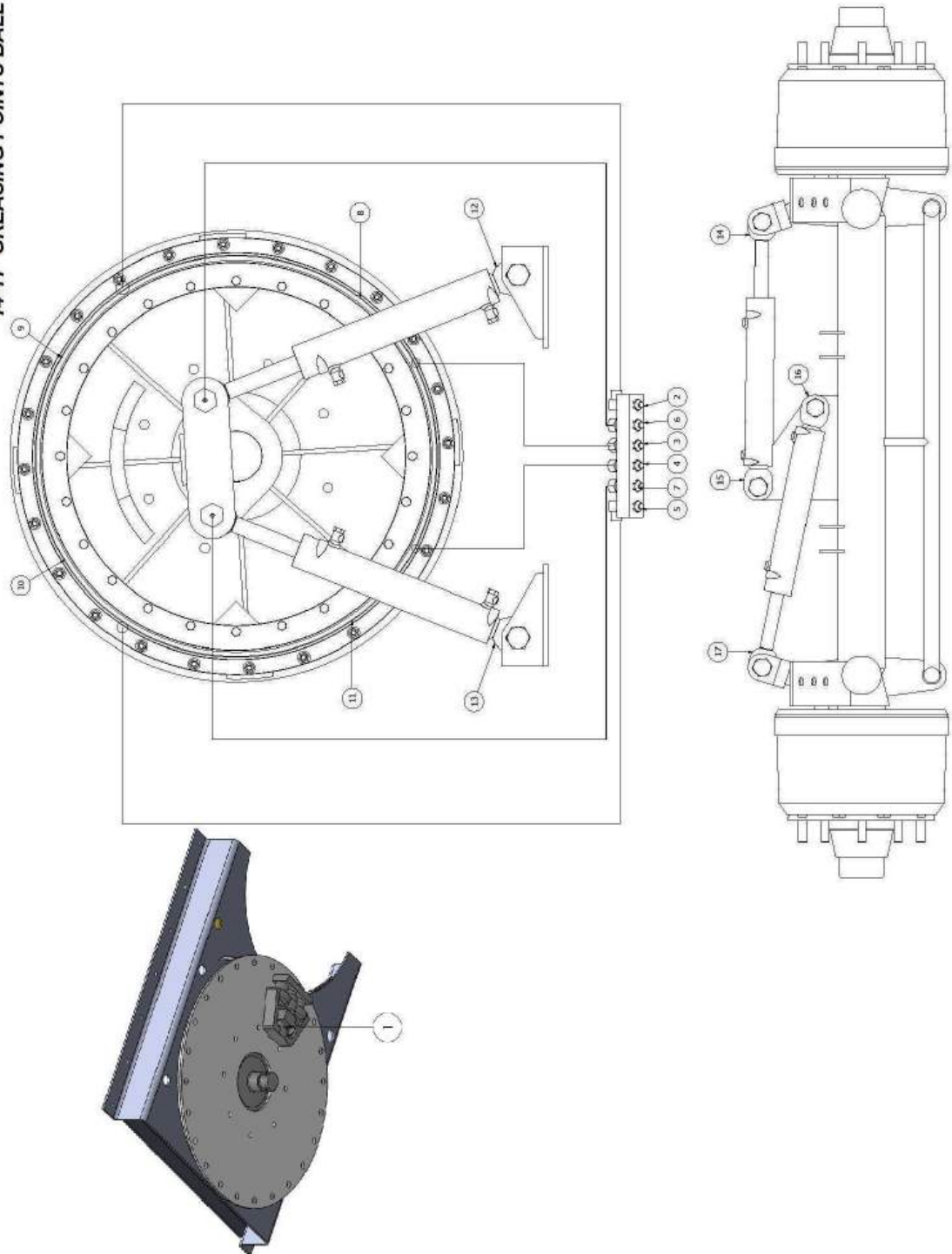

HYDRAULIC CIRCUIT, CYLINDERS IN FRONT OF THE AXLE

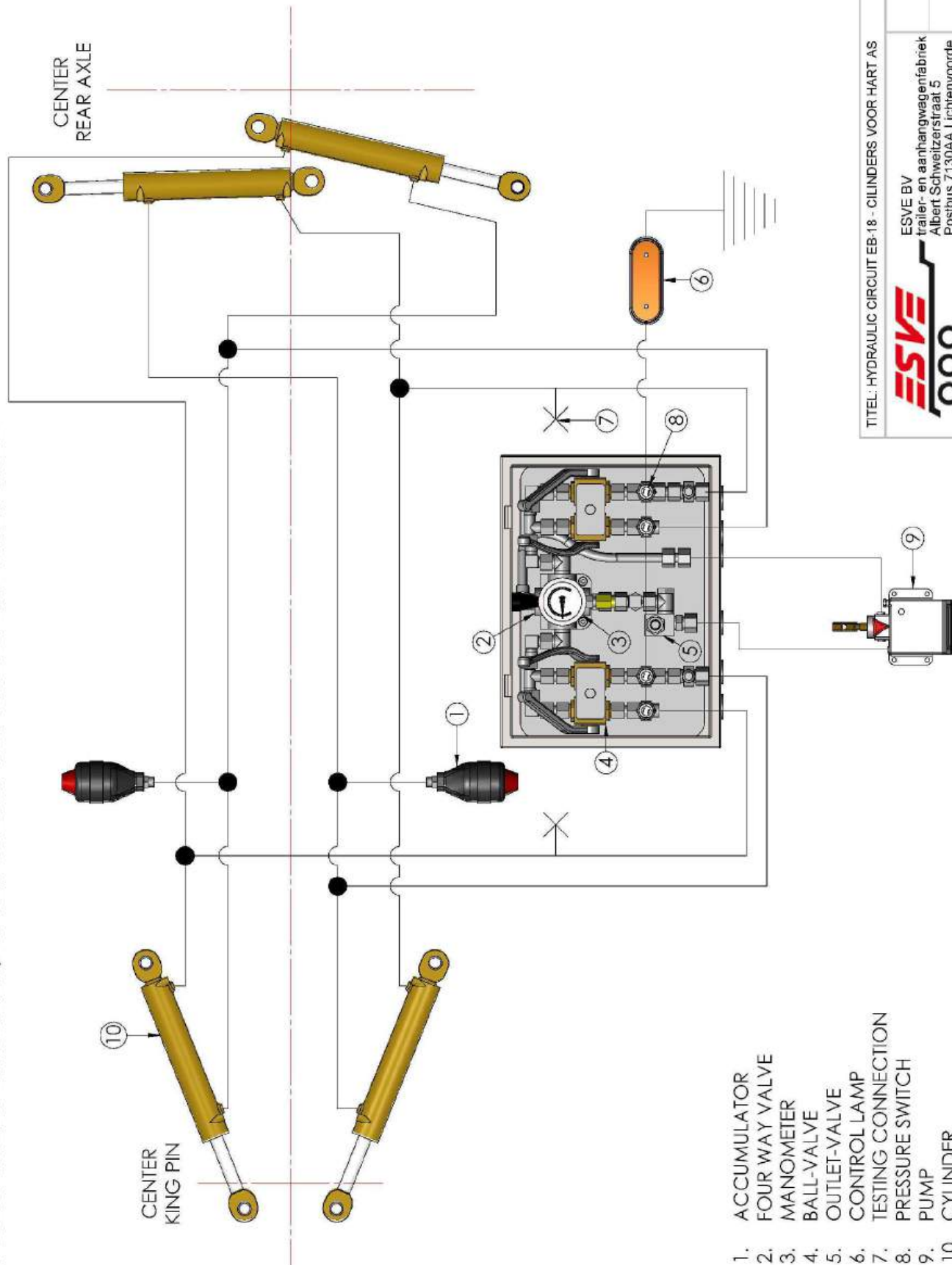

- 1. ACCUMULATOR
- 2. FOUR WAY VALVE
- 3. MANOMETER
- 4. BALL-VALVE
- 5. OUTLET-VALVE
- 6. CONTROL LAMP
- 7. TESTING CONNECTION
- 8. PRESSURE SWITCH
- 9. PUMP
- 10. CYLINDER

TITEL: HYDRAULIC CIRCUIT EB-18 - CILINDERS VOOR HART AS

**ESVE**  
**000**  
**SPECIAL TRAILERS NL**

ESVE BV  
 trailer- en aanhangwagenfabriek  
 Albert Schweitzerstraat 5  
 Postbus 7130AA Lichtenvoorde  
 Tel: 0544-392450

DATUM:  
 02-03-2017  
 TEK. NR. :  
 . . .

SCHAAL: - A3

# HYDRAULIC CIRCUIT, CYLINDERS BEHIND THE AXLE

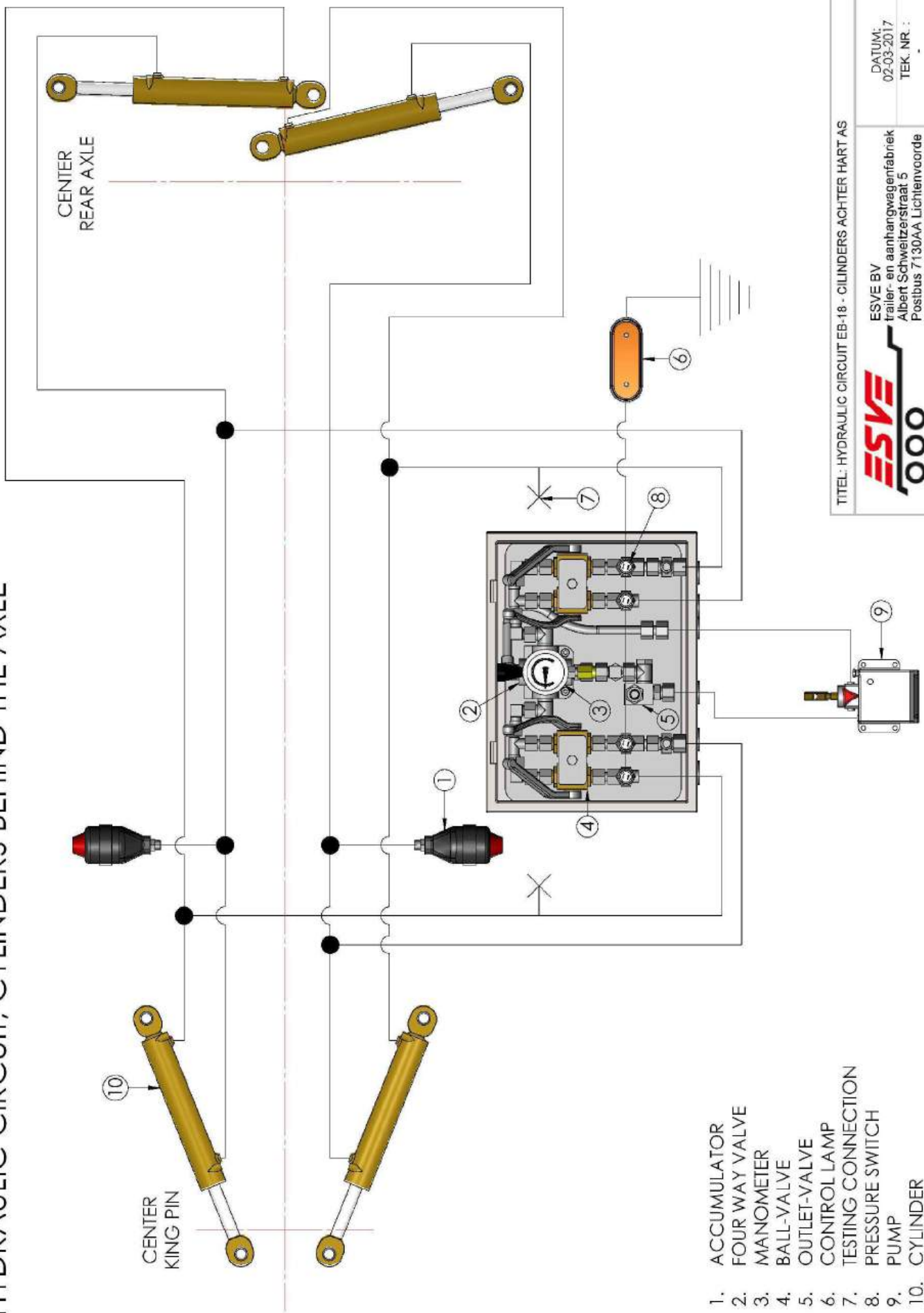

1. ACCUMULATOR
2. FOUR WAY VALVE
3. MANOMETER
4. BALL-VALVE
5. OUTLET-VALVE
6. CONTROL LAMP
7. TESTING CONNECTION
8. PRESSURE SWITCH
9. PUMP
10. CYLINDER

TITEL: HYDRAULIC CIRCUIT EB-18 - CILINDERS ACHTER HART AS



ESVE BV  
 trailer- en aanhangwagenfabriek  
 Albert Schweizerstraat 5  
 Postbus 7130AA Lichtenvoorde  
 Tel. 0544-392450

DATUM: 02-03-2017  
 TEK. NR. :

SCHAAL: - A3